

SlimLiner+ 30/40/54:1 Gearbox

FEB 2003

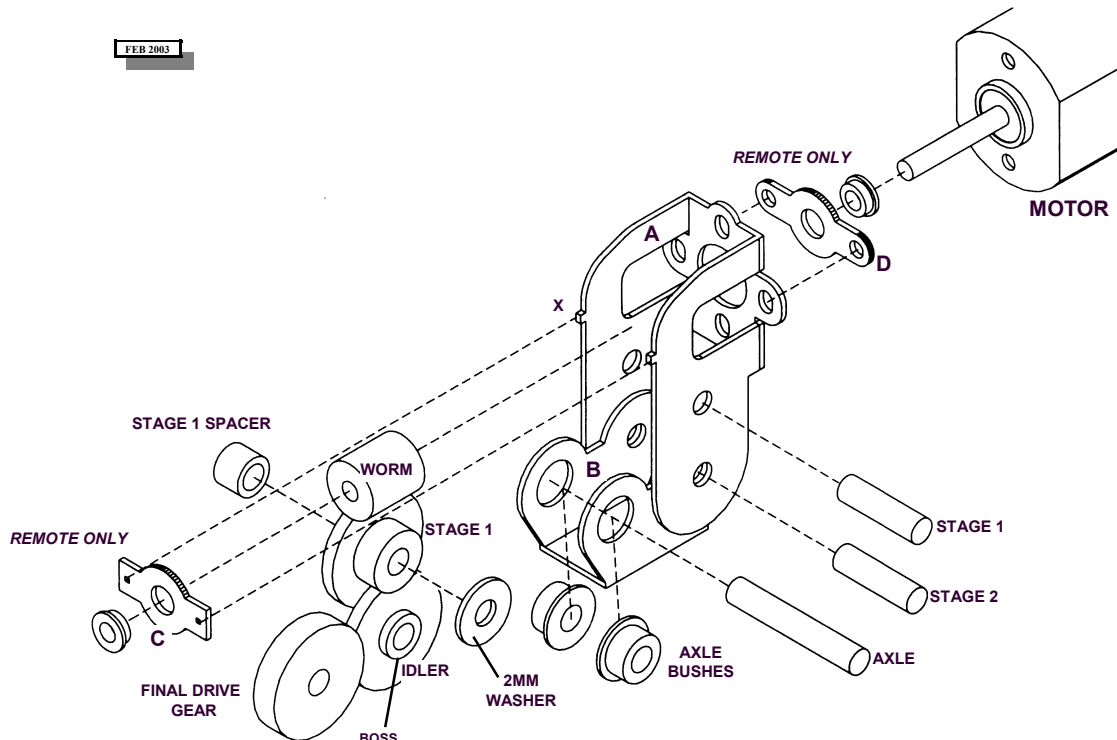

FIG. 1

Study Figs 1 and 2. Before cutting the gearbox etch from the fret, progressively ream out each of the **holes** to the sizes shown in Fig 2. Components should be offered up until they a tight push-fit in their holes. Once the gearbox is assembled, the shafts are fixed but the gears are free to revolve. Remove burrs by inserting the tip of a drill bit (of much larger diameter than the hole) and gently rotating it between your fingers.

The axle bushes will be one of two types, depending on the axle diameter. Solder the **axle bushes** into place on the final drive carriage (B) with the larger-diameter shoulders on the same side of the etch as the bend lines. You can file the outside (non-shouldered) face of the bush flush or, alternatively, file the bushes to length so they eliminate any sideplay on the gearbox when fitted into the chassis. Remove burrs as above. Check that the motor mounting screws will pass through their slots and into the motor.

The kit includes the additional etched components (C, D) you will need to convert the gearbox into a remote-drive system, using cardan shafts linked to the motor by universal joints. The last will need to be sourced separately - Formil, NWSL and Exactoscale produce suitable designs. As the diameter of the input/output shaft varies between makes, you will need to provide your own bearings to fit into our remote drive attachments. Ordinary 'straw hat' bearings available from Gibson, Sharman etc. will work reasonably well but for a proper engineering job, try to get some turned up from sintered bronze. The worm driveshaft should ideally be of hardened steel (like a motor shaft) but again, the silver steel supplied with the kit will do at a pinch. Before beginning construction, read the notes overleaf, covering remote drive attachments.

If you intend to use the **remote drive attachments**, open out their central holes to accept either a 1.5mm or 2mm bore bush, depending upon the diameter of your motor shaft. Solder these bushes into their holes, making sure they sit dead square.

Now cut the etches from the fret with a heavy blade and trim off the tabs, taking care not to accidentally remove any locators. **Fold up the gearbox** (A) as shown in Fig. 1, using flat nosed pliers to grip the motor mounting plate near the bend lines when doing so. This will prevent the plate from accidentally buckling across the hole centres. All bends are 90°, with the bend lines on the inside of the gearbox. Add fillets of solder to the inside of the folds to strengthen the gearbox. If you are using the **remote attachments**, open out the small location holes in the front attachment (C) so they fit snugly over the locators (X) on the main gearbox etch, and then solder it in place. Now fold up the final drive carriage (B) and strengthen with solder, as above. De-flux the gearbox and carriage by scrubbing them with household cleaner, then rinse and allow to dry. If they are likely to be visible then **paint** them black.

Using a carborundum disc in a mini-drill, cut the stage 1 and idler **gearshafts** so their length equals the overall width of the gearbox. Wear effective eye protection – cutting discs can and do disintegrate if they snag. Remove any burrs with a fine file. If shafts are a tight fit, you will only be able to pass them through both sides of the etches if they are truly square. If they won't go through, then the etches haven't been folded accurately. Light finger tweaking should put things right.

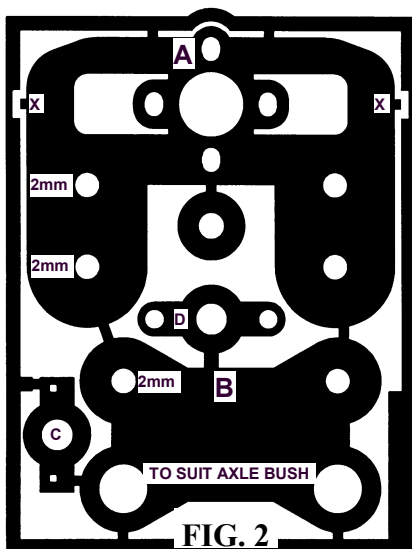

Push the **worm** onto the motor shaft until its mid-point is 6mm from the front face of the motor. The worms provided may be either **brass or nylon**, according to type and gear ratio (they are not interchangeable). The nylon type worms should be a firm push fit on the motor shaft. Some brass worms supplied to us are fractionally tighter than others and if they aren't an easy push-fit, they can be gently forced onto the shaft in a vice. Don't use excessive force or the shaft may bend. Instead, use a broach to ease the fit of the worm and then, if necessary, secure the brass worm with a small drop of Loctite 601 at the outer end of the motor shaft.

A variety of **motor fixings options** is provided, to allow for different motor types. The vertical slots will accommodate the Mashima 10 series motors (these have 8.5mm mounting screw centres) as well as narrower open-framed motors, such as the Mashima 9/16 (which have 8mm screw centres). The horizontal slots are spaced to suit the 10 series only. If possible use the latter as this will allow you to fit (and remove) the motor once the power unit is assembled and installed in the chassis. This will enable you to add wheels, valve gear and other fittings to a free-rolling chassis, and makes it much easier to identify and put right any tight spots or clearance problems. The motor can be removed or refitted at any stage of construction.

If clearance restrictions dictate that the vertical motor mounting holes must be used, we suggest that the motor is fitted before the Stage 1 gearshaft and then the latter is lightly glued at one end only. Should the motor require attention, then the gearshaft can be easily removed by gently tapping it out with a drift. If you are using these vertical motor mounting holes, you can now **fit the motor** and worm assembly onto the gearbox and secure it with the fixing screws supplied with the motor.

Refer to Fig. 1. The stage 1 double gear will be one of three types - 15/10T (30:1), 20/10T (40:1) or 27/10 (54:1) - depending on the overall reduction ratio of the gearbox. Fit the **stage 1 gearshaft**, double gear (according to ratio) the spacer bush and the etched thrust washer (with the ribbed side facing the gear) into the gearbox. Sight through the opening in the gearbox sides to check the mesh with the worm - there should be daylight between the gear and the worm, but avoid having too much backlash. Some modellers may prefer a deeper mesh (especially for a heavily loaded loco) but avoid 'bottoming out' the gears. If the mesh is too shallow, the gears may wear or even come out of mesh. If necessary, loosen the motor fixing screws, adjust the mesh and then lightly glue the shaft in place.

The **final drive carriage** can be mounted facing backward or forward, depending on the configuration you require. Offer up the final drive carriage and slot the **idler gearshaft** through the carriage and gearbox, slipping on the thin 20T. gear as you do so. (Note that the larger boss on this gear runs nearest the gearbox side). Secure the shaft to the carriage side using a tiny amount of glue. The unit will run smoothly if the final drive carriage is free to pivot about the idler shaft, but suitable restraint must be provided for the gearbox and motor in order to prevent the carriage from curling up on itself when torque is applied. It may be preferable fix the final drive carriage in one position (this position can be determined later, when the gearbox is installed).

Temporarily fit the final **brass 20T.** gear and axle into the final drive carriage. If the motor is not fitted, check that all the gears revolve smoothly. Now **test the gearbox** under power by fitting the motor and worm assembly as described above. Remove the drive axle and brass gear. Fit the gearbox into the **chassis** by slotting the axle through the frames, the gearbox and the brass gear, making sure the latter is correctly meshed with the idler gear. You may need to fit washers between the gearbox sides and the frames in order to prevent the gearbox from moving sideways on the axle. It is also advisable to fit washers behind the wheels on this axle in order to eliminate any sideplay. When you are happy with the position of the gear and gearbox on the axle, glue the brass gear to the axle using tiny spots of Loctite 601 applied with a pin. Rotate the axle to ensure an even distribution of the adhesive.

To use the **remote drive attachments** push the worm onto the driveshaft so that 3mm of the shaft is protruding and secure the worm with Loctite if necessary. Slot the short end of the shaft through the motor mounting plate and into the bearing in the front remote attachment (C). Slot the rear remote attachment (D) over the opposite end of the driveshaft and slide it up to the motor mounting plate (The gearbox can be driven from the opposite end by reversing the shaft). Work out how many washers you will need to centre the worm directly over the stage 1 gear and eliminate endfloat. Remove the shaft assembly, fit the washers on either side of the worm and then refit the shaft along with the washers. Secure the rear remote attachment to the motor mounting plate using 12B.A. nuts and bolts through the side holes. With the bolts partially tightened, position the attachment so its circular middle sits centrally over the hole in the motor mounting plate (like lining up a gun sight). Tighten up the bolts and test the gearbox. The worm and drive shaft can be removed at any time simply by unbolting the front remote attachment plate.

The gears are effectively self-lubricating but a little plastics-compatible grease will do no harm. Do not use general-purpose modelling oil, which attracts dust and grit. Metal-on-metal contact areas (motor bearings, axle bushes) should be lubricated with a tiny amount of Zeuthen ultra-adhesive oil.

FOR MORE INFORMATION ON HIGH LEVEL *PRECISION* GEARBOXES CONTACT
HIGH LEVEL, 14 TUDOR ROAD, CHESTER-LE-STREET, CO. DURHAM, DH3 3RY.

WEBSITE - WWW.HIGHLEVELKITS.CO.UK

E MAIL - ENQUIRIES@HIGHLEVELKITS.CO.UK